

orbital weld-on ball valve  
3-piece, full bore PN 63  
voller Durchgang

[short name: ORK3\\*](#)

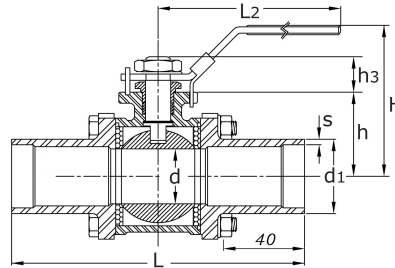

### technical product sheet

DN	Zoll	d1	s	d	L	l	H	h	h3	L2	kg	Art.-Nr.
15	1/2"	21,3	2,0	15	124	40	61	29,0	19,5	134	0,534	ORK3-21
20	3/4"	26,9	2,0	20	132	40	64	33,0	27,5	134	0,779	ORK3-26
25	1"	33,7	2,0	25	140	40	68	37,5	25,5	134	1,035	ORK3-33
32	1 1/4"	42,4	2,0	32	149	40	79	43,0	29,7	134	1,588	ORK3-42
40	1 1/2"	48,3	2,0	38	165	40	96	48,5	35,5	195	2,332	ORK3-48
50	2"	60,3	2,0	50	176	40	100	58,5	35,5	195	3,226	ORK3-60

available material: V4A

Industrial valves > ball valves > butt weld ends > orbital weld-on ends > ISO-range

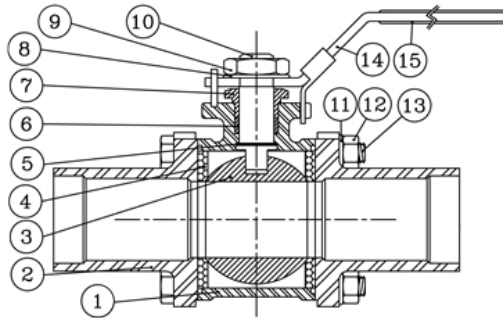
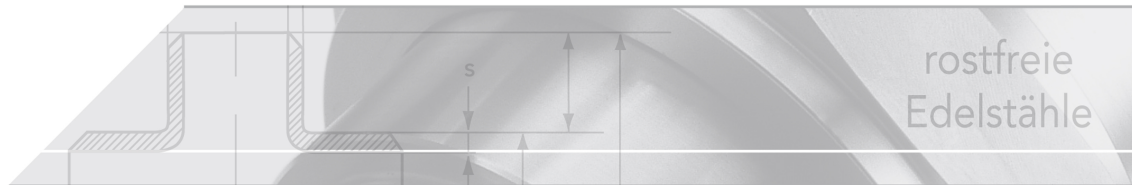

### Parts list

No.	Designation	Material
1.	Housing	V4A (ASTM CF8M)
2.	Flange (2x)	V4A (ASTM CF8M)
3.	Ball	V4A (ASTM CF8M)
4.	Seat seal (2x)	PTFE
5.	Pressure seal	PTFE
6.	Shaft seal (2x)	PTFE
7.	Stem packing	V2A (AISI 304)
8.	Washer	V2A (AISI 304)
9.	Nut	V2A (AISI 304)
10.	Control shaft	V4A (AISI 316)
11.	Washer (4x)	V2A (AISI 304)
12.	Nut	V2A (AISI 304)
13.	Hexagon head screw (4x)	V2A (AISI 304)
14.	Handle	V2A (AISI 304)
15.	Coating	PVC (blue)
16.	Locking device	V2A (AISI 304)

### ISO top Flange plate acc. to ISO 5211

for direct mounting on the actuator

DN	ISO	P	I	M	N	W
15	F03	32	37	5	13	M5x0,8
20	F03	32	37	5	13	M5x0,8
25	F04	42	42	6,5	14	M5x0,8
32	F04	42	42	6,5	14	M5x0,8
40	F05	50	50	8,5	17,5	M6x1,0
50	F05	50	50	8,5	17,5	M6x1,0

## Mounting

Before welding the ends of the connections, the middle section of the ball valve must be disassembled to prevent damaging the seals.

1. Clamp the valve carefully in a vise. You can prevent damage to the ends of the housing using protective wedges. Unscrew the hex-head nuts crosswise and pull the screws out of the housing. Remove the middle section of the ball valve. Make sure that the seals and the ball do not fall out of the housing. Place the parts aside with care. You should mark the ends order to be able to determine which ends are for connection later during reassembly.

2. Mount a piece of tube with a length equal to that of the middle section between the ends of the connections.

3. Allow the ends of the connections to cool off adequately before you install the middle section.

Remove the piece of tube mentioned above.

Push the middle section of the ball valve between the ends of the connection.

If necessary, orient the middle section so it attaches to the corresponding ends of the connection.

Make sure that all seals are seated properly and that there is no dirt or contamination on the seals or the ball.

Push the hex-head screw through the holes in the ends of the connection. Tighten the nuts evenly by tightening them crosswise. Note the maximum torque of the screws when tightening.

Test the function of the ball valve. Test all connections to ensure they do not leak.

## Maintenance and inspection

The ball valves are maintenance-free under normal operating and ambient conditions. However, the following inspections should be performed at regular intervals depending on the frequency of activation and the operating conditions:

### > Check the spindle seal for leaks

If the seal is failing, then the stem packing must be tightened at operating pressure.

Tighten the nut until the spindle seal is tight again and does not leak any more.

Make sure that the ball valve is still easy to operate.

### > Testing the ball seal for leaks

If the seal is not tight enough, the ball and/or the seal set of the ball valve can be replaced.

For 3-part ball valves, you only need to remove the middle part of the ball valve.

*You absolutely must follow our installation and operating instructions!*

*see [www.heco.de/Downloads/Instructions](http://www.heco.de/Downloads/Instructions)*

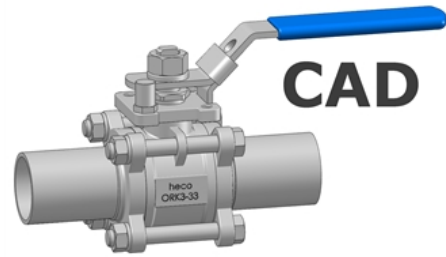
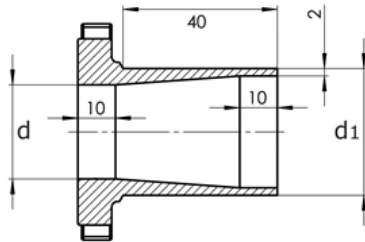
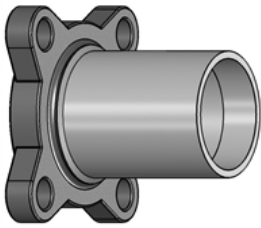
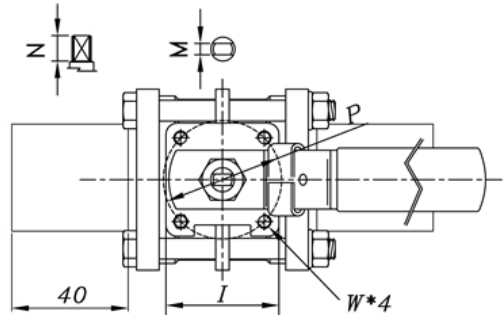
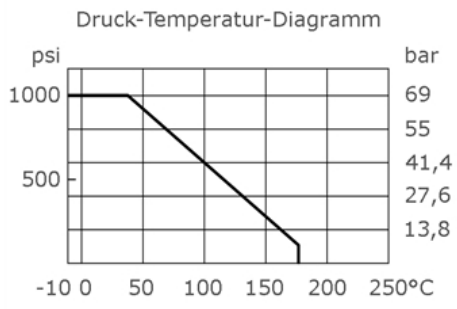

**CAD**

als 3D-Modell verfügbar